

Prod. code: 145 9278

Instruction manual for mobile rack for gymnastics, aerobics and standard dumbbells

Thank you very much for choosing a **SPORT-THIEME** product.
Please read the instructions fully before you assemble the equipment so you
can enjoy the product and its guaranteed safety:

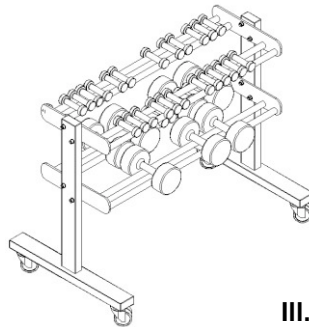

III. 1: Rack

Included:

<u>Pos.</u>	<u>Description</u>
1	2 x side panel with mounted double castors
2	2 x pre-assembled shelves
3	8 x socket screw M10 x 60 with nuts and 2 washers

1. Assembly instructions

Assemble the parts as shown in ill. 2. For this, you need an 8 mm hex key.

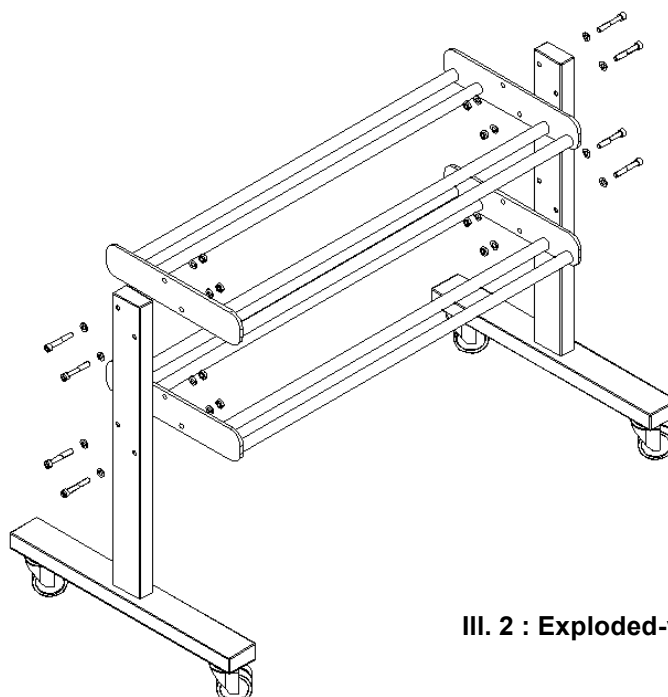

III. 2 : Exploded-view drawing

Prod. code: 145 9278

The equipment is designed solely for transporting and storing of dumbbells. It is not suitable for transporting people or other objects.

Caution: Do not overload or climb the equipment!



Maintenance and care instructions

Instructions:

Carry out a visual check at regular intervals. Due to our continuous quality control of the products, technical changes may occur which may lead to slight deviations in the instructions. Check at regular intervals that the screw connections are tight. Check the equipment for possible damage and replace worn-out parts. Ensure that moveable parts are free-moving.

We are happy to answer any questions you may have.

Your **Sport-Thieme** Team