

Scharnierachse (2)  
Hinge Pin (2)  
Art.-No. C 203



O-Ring (4)  
O-Ring (4)  
Art.-No. C 210



Scharnierteil A (2)  
Hinge Part A (2)  
Art.-No. C 202 A



Brettschraube  
mit Scheibe und Mutter (2)  
Board Bolt with  
Washer and  
Nut (2)  
Art.-No.  
SF 122/135



Nylonbuchse (8)  
Nyliner (8)  
Art.-No. C 209



Komplettes Scharnier (Teil 1-3)  
mit Befestigungsschrauben (2)  
Hinge with Aluminum  
Bolts – complete (2)  
Art.-No. C 202



Scharnierteil B (2)  
Hinge Part B (2)  
Art.-No. C 202 B



Scharnierbefestigungsschraube  
(weiß mit Mutter) (8)  
Aluminum Hex Head  
Bolt with Nut (8)  
Art.-No.  
SF 106/  
SF 110



Endlager  
*Short-Stand Anchor-Fitting*  
Art.-No. SB-501-E



Endlager  
mit Scharnieren und  
Brettschrauben  
*Short-Stand Anchor Fitting  
Assembly with Hinges  
and Board Bolts*  
Art.-No. SB-550-E



**C-250-I**  
Endlager für 1- und 3-Meter Stände  
*1- and 3-meter anchor fitting ass'y*

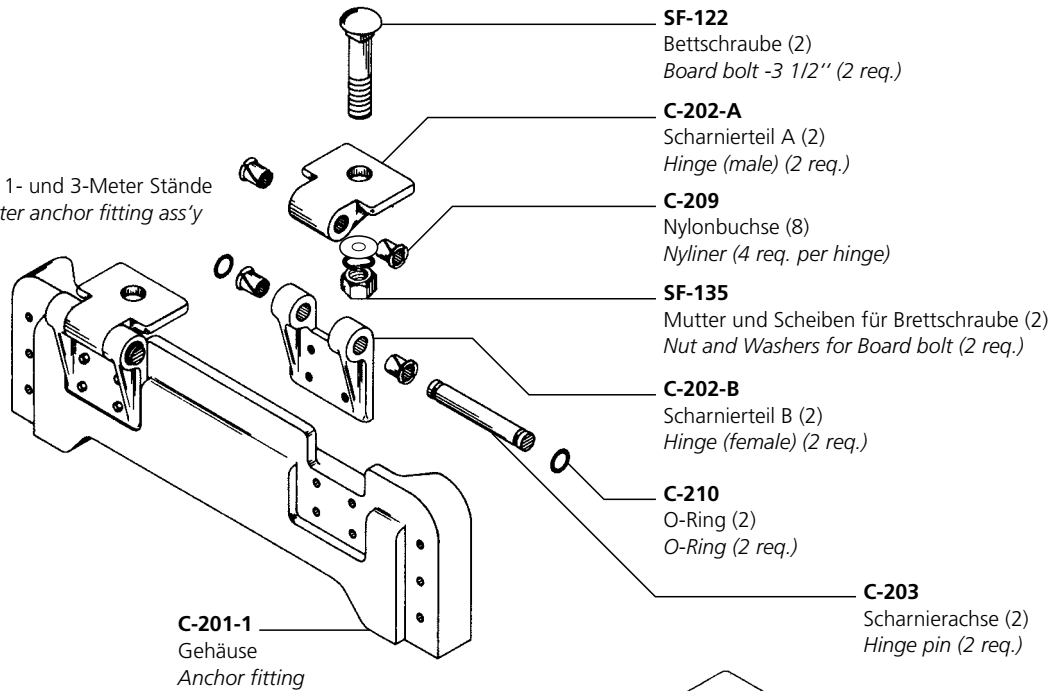

**SF-122**  
Bettschraube (2)  
*Board bolt -3 1/2" (2 req.)*

**C-202-A**  
Scharnierteil A (2)  
*Hinge (male) (2 req.)*

**C-209**  
Nylonbuchse (8)  
*Nyliner (4 req. per hinge)*

**SF-135**  
Mutter und Scheiben für Brettschraube (2)  
*Nut and Washers for Board bolt (2 req.)*

**C-202-B**  
Scharnierteil B (2)  
*Hinge (female) (2 req.)*

**C-210**  
O-Ring (2)  
*O-Ring (2 req.)*

**C-203**  
Scharnierachse (2)  
*Hinge pin (2 req.)*

**C-201-1**  
Gehäuse  
*Anchor fitting*

**SB-550-E**  
Endlager für Short Stands  
*Short stand anchor fitting ass'y*

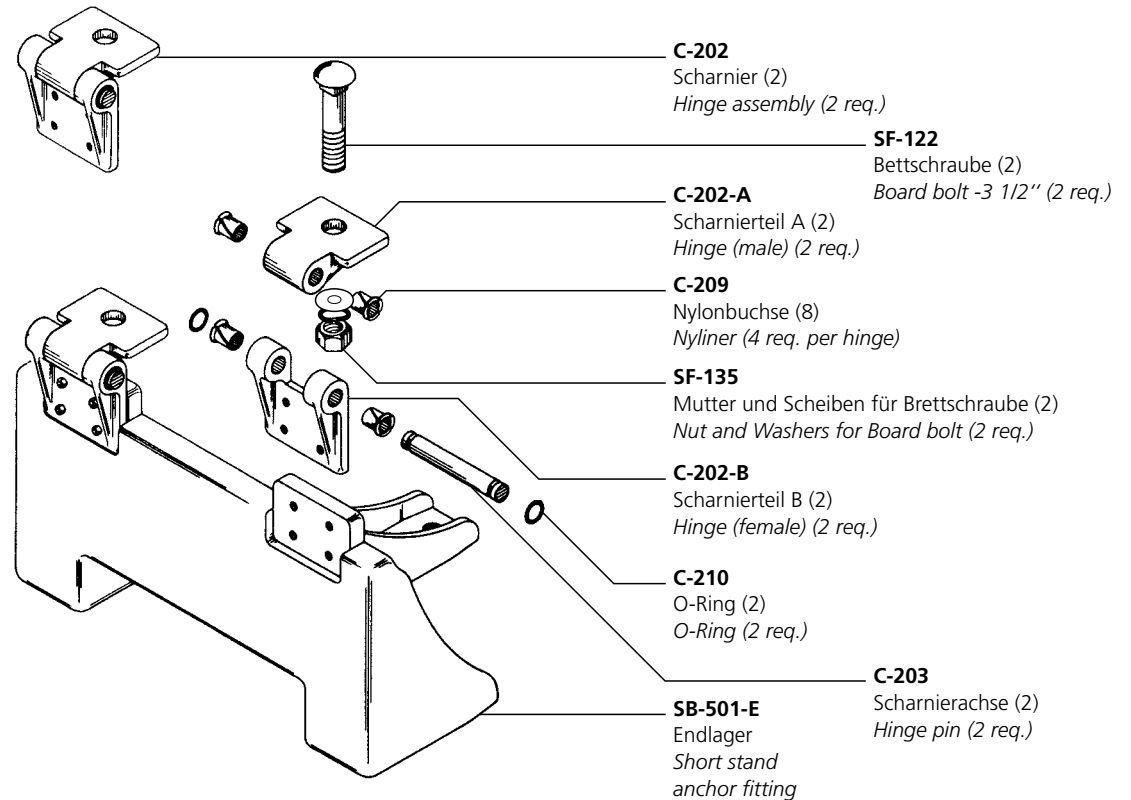

**C-202**  
Scharnier (2)  
*Hinge assembly (2 req.)*

**SF-122**  
Bettschraube (2)  
*Board bolt -3 1/2" (2 req.)*

**C-202-A**  
Scharnierteil A (2)  
*Hinge (male) (2 req.)*

**C-209**  
Nylonbuchse (8)  
*Nyliner (4 req. per hinge)*

**SF-135**  
Mutter und Scheiben für Brettschraube (2)  
*Nut and Washers for Board bolt (2 req.)*

**C-202-B**  
Scharnierteil B (2)  
*Hinge (female) (2 req.)*

**C-210**  
O-Ring (2)  
*O-Ring (2 req.)*

**C-203**  
Scharnierachse (2)  
*Hinge pin (2 req.)*

**SB-501-E**  
Endlager  
*Short stand anchor fitting*

Änderungen können ohne Benachrichtigung vorgenommen werden. Wir behalten uns vor, Produkte abzuändern oder ganz aus dem Lieferprogramm zu streichen. Die Angaben in diesem Katalog sind ohne Gewähr.

Der Nachdruck bzw. die Kopie auch von Teilen dieser Dokumentation, sowohl auf elektronischem wie auch mechanischem Weg, bedürfen unserer ausdrücklichen schriftlichen Genehmigung.

© Copyright – Alle Rechte vorbehalten

*Changes may be made without further notice. We reserve the right to change products or omit them from our program. The information given in this catalog is subject to change.*

*No part of this publication may be reproduced by any means, electronic or mechanical, including photocopying and microfilming, or utilized in any other form without permission in writing from the publisher.*

© Copyright – All rights reserved

Flister Group GmbH & Co KG  
Dorfäcker 4  
D-91086 Aurachtal  
Tel.: +49 (0) 91 32-30 01  
Fax: +49 (0) 91 32-65 02  
eMail: [info@duraflex.de](mailto:info@duraflex.de)  
web: [www.duraflex.de](http://www.duraflex.de)



**FLISTER**  
Duraflex Equipment